

Outdoor rated 40W Laser

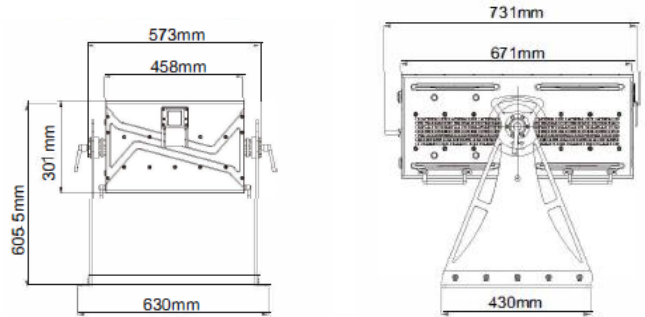

Features

- IP65 high-power outdoor waterproof laser
- American pangolin technology
- high-speed galvanometer control technology, National Electrical Product Safety and Quality scientifically designed waterproof and dustproof structure, heat dissipation
- high-end atmospheric appearance, create a high-security performance aerial laser



Technical Specifications

Rated voltage: AC100~240V 50/60Hz
 Power consumption: 1800W
 Scanner : 30kpps landmark scanner, scan angle: Max±30°;
 Input signal: ±5V; Linearity distortion<2%)
 Modulation: analog @Control mode:FB4/
 automatic/master
 slave/DMX512(15CH) /ethernet
 Control interface: Waterproof DMX512 interface,
 waterproof
 ethernet interface
 Beam diameter and divergence: 11*6.5mm;1.2mrad
 Range: the head can rotate 360°

IP rate: Ip65 (outdoor)
 Application: cityscape, architectural landmark, laser show,
 advertising promotion, etc.
 Size: 82*73*82cm
 N.W./G.W.: 94kg/131 kg

