

## 150 W LED Wash Pixel Moving Head

### Features

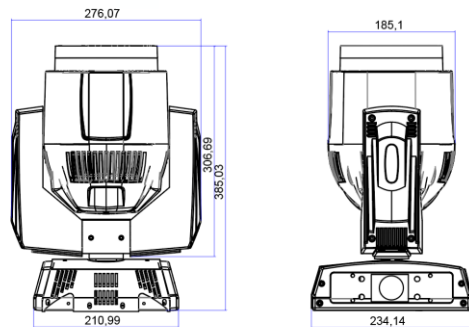

- High-performance wash effect, beam effect and visual effects
- 7PCS 15W 4-in-1 RGBW LEDs
- Supports RDM DMX
- Beam ranges from 4° to 60°
- Unlimited possibilities and effects with individual control of each LED.



### Technical Specifications

#### SPECIFICATION

Source: 7\*15W 4-in-1 RGBW LEDs  
 Flicker free operation  
 Life Span: 50000H  
 150W Power consumption

#### OPTICS

4°-60° Beam angle  
 360° Continuous front lens rotation with variable speed  
 Pixel mapping capability with each LED  
 Preset color macros

#### CONTROL

Display: LCD display  
 17/23/43 DMX channels USITT DMX-512  
 DMX512, master-slave, sound activated or auto operation  
 DMX recorder and edit function integrated  
 RDM available  
 Art-NET (Optional)  
 3-Pin XLR DMX connectors IN/OUT

#### CONSTRUCTION

Moulded fireproof ABS PC  
 Aluminum and steel metal plates  
 IP20 protection rating

#### PHYSICAL

Product Dimensions:  
 211(D)\*276(W)\*385(H)mm  
 Packing Dimensions:  
 300(D)\*360(W)\*450(H)mm  
 N.W.: 7.5kg  
 G.W.: 8.5kg